

# VANTAGE ACF-18

Model E023018VTG



## Specifications

- Materials
  - Tanks: Polyethelene
  - Various: PVC
  - Solenoid: Brass, Viton, EPDM
- Dimensions
  - See drawing
- Weight Empty
  - 45 lbs
- Weight Full
  - 63 lbs
- Operating Temperature
  - 30-104°F
- Inlet Pressure
  - 10-45 psi
- Nominal Influent Operating Pressure
  - 10-30 psi
- Tablet Capacity (Vantage Calcium Hypochlorite Tablets)
  - 18 lbs.
- Maximum Chlorine Output (available chlorine per day)
  - 14.6 lbs.

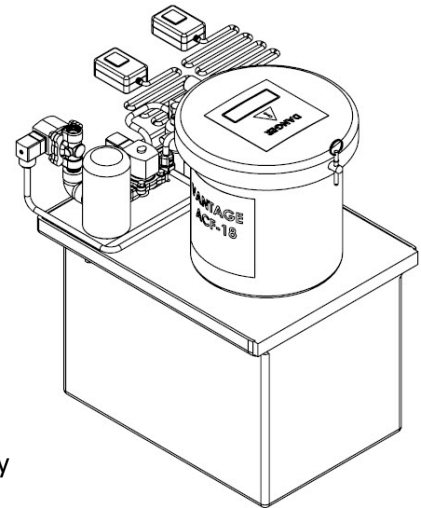

## Electrical

- Inlet solenoid Valve
  - 115 VAC for included power supply
- Chlorine feed solenoid valve
  - 115 VAC for included power supply or 12 VDC from pool controller
- Booster Pump
  - 115 or 230 VAC
  - Interlock to pool circulation pump

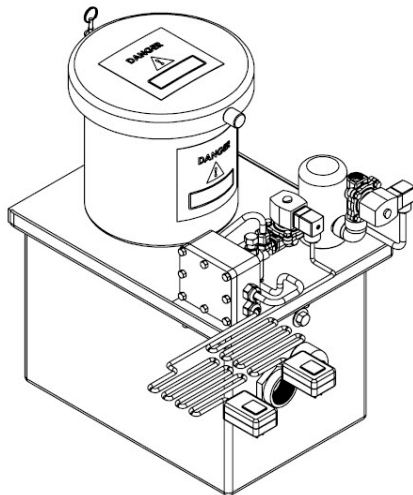

## Plumbing Connections

- Feeder inlet
  - ½" female NPT
- Feeder effluent
  - ½" female NPT
- Eductor inlet
  - ¾" female NPT
- Eductor effluent
  - 1" male NPT
- Eductor suction
  - 1" female NPT
- Manual overflow to drain
  - 1" female NPT
- Booster pump inlet
  - ¾" female NPT
- Booster pump effluent
  - ¾" female NPT

## Certifications

- Vantage ACF-18 Feeder



Certified to NSF/ANSI Standard 50

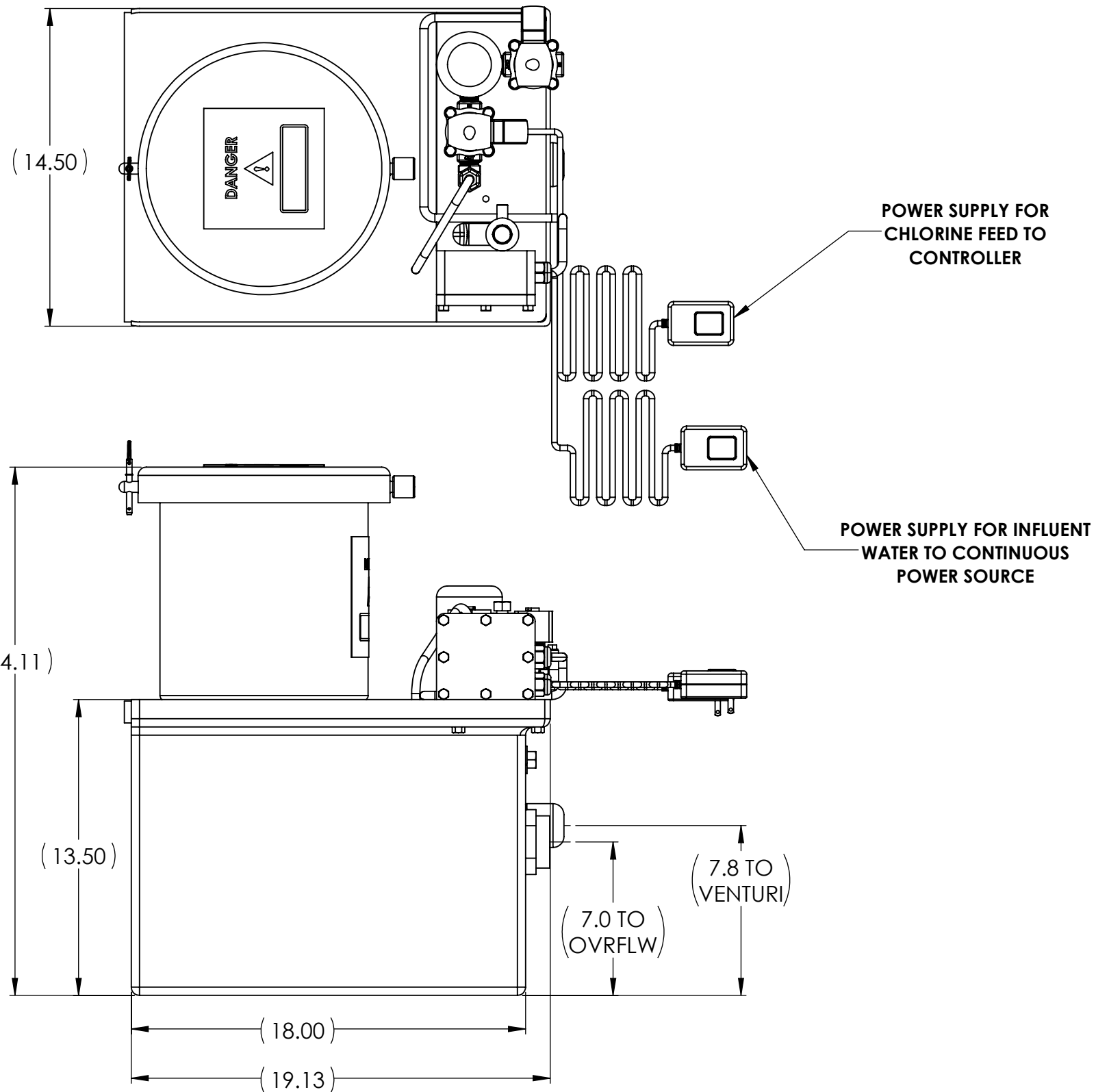
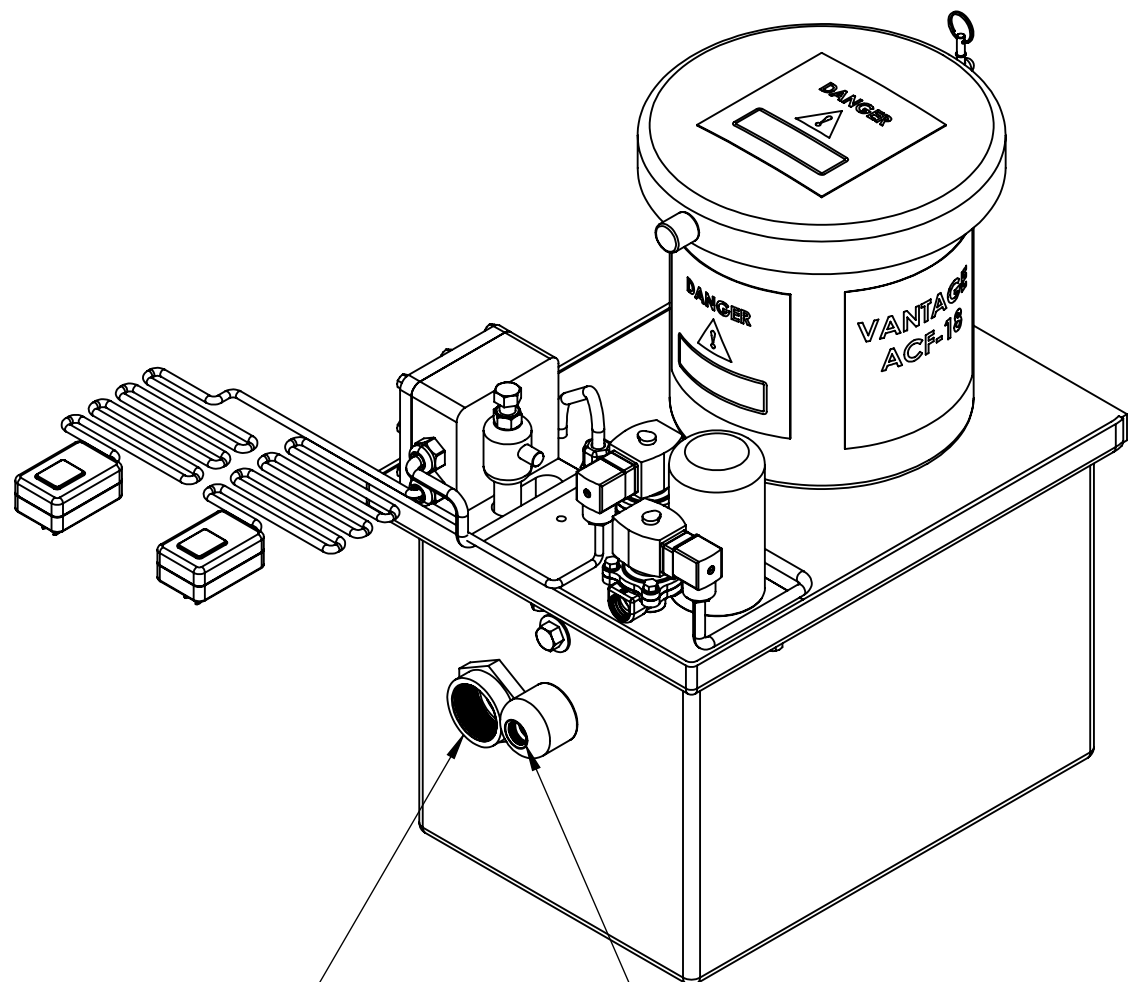

OVERFLOW TO DRAIN  
1" FIPT

FEEDER EFFLUENT 1/2" FIPT  
TO VENTURI

**NOTES:**

1. INSTALL ITEMS AS SHOWN IN SCHEMATIC. ADDITIONAL INFORMATION FOUND IN I&O MANUAL.
2. WEIGHT EMPTY: 45 LBS
3. WEIGHT FULL: 63 LBS

DESCRIPTION: ASSY, VANTAGE MODEL ACF-18 NO SKID			
MATERIAL: SEE BOM		AllChem Performance Products 416 South Main Street Corsicana, TX 75110	
<small>PROPRIETARY AND CONFIDENTIAL</small>			
<small>THE INFORMATION CONTAINED IN THIS DRAWING IS THE SOLE PROPERTY OF ALL CHEM PERFORMANCE PRODUCTS. ANY REPRODUCTION IN PART OR AS A WHOLE WITHOUT THE WRITTEN PERMISSION OF ALL CHEM PERFORMANCE IS PROHIBITED.</small>			
SIZE B	MODEL NO: E023018	REV: A	
SCALE: 1:6	STATUS:	SHEET: 1 OF 1	
<small>© 2016 ALL CHEM PERFORMANCE</small>			